

# IT3000CE - LED

3-1/2" 3000 Series - Evolution LED

Project	
Notes	
Fixture Type	
Date	

## IC Air Tight Short Remodel Housing with Electronic Transformer for MR16 LED Lamp

### SPECIFICATIONS

**HOUSING DETAILS** 18 gauge 0.051" (1.3 mm) thickness galvanized steel.  
 Approved for use in insulated ceilings in direct contact with the insulation material (except polyurethane).  
 Air Tight.  
 Flexible channel wire bracket made of 20 gauge steel, bending up to 45° vertically for ease of installation in confined spaces.  
 Junction box can support up to 10 – 14 gauge wires or 8 – 12 gauge wires.  
 Below-ceiling accessible.

**MOUNTING** **Cutout diameter: Ø 3-5/8" (92 mm)**  
 Can fit in ceilings from 1/2" (13 mm) up to 1-1/8" (29 mm) thick.  
 Requires a 4-3/4" (121 mm) clearance beyond the ceiling level.  
 Hook for ease of installation and a perfect fit to ceiling.  
 No light leakage.

**LAMP** **MR16 LED GU 5.3 11.5W MAX**

**VOLTAGE** 120 Volts

**TRANSFORMER** Electronic Transformer  
 Hatch A/C LED, 15W 120V/12V (RS12-15M-LED)  
 Dedicated to LED Lamps

**DIMMING** During Product Development Contrast tested some dimmers that you will find by consulting regularly the dimmer compatibility list on our website at ([www.contrastlighting.com](http://www.contrastlighting.com)).  
 Constant progresses in LED lamps and dimmers technologies may offer change in compatibility options that you will find by consulting frequently the lamp manufacturer compatibility list.

<b>COMPATIBLE TRIMS</b>	R3151	S3145	T3125	T3185	T3400D
	R3151W	S3151	T3145	T3200	T3450
	R3152	S3400	T3145D	T3250	T3450D
	R3171	S3450	T3145DG	T3250DG	T3450W
	R3450D	S3450D	T3145W	T3260	T3650
	R3470	T3000	T3152	T3300	T3652
	R3652	T3100	T3165	T3400	T3850

**THERMAL PROTECTION** TC 194°F (90°C)

**HOMOLOGATION** • cULus **E343977** for damp locations  
 • Certified Air Tight ASTM E283

**WARRANTY** 5 years on socket and 3 years on electronic transformer.

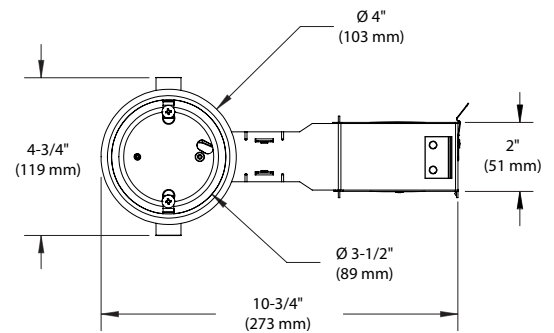
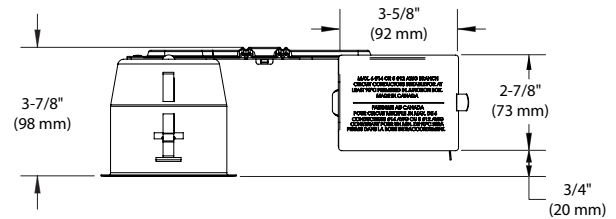

# CONTRASTE

# IT3000CE-LED

3-1/2" 3000 Series - Evolution LED

## CODIFICATION EXAMPLE

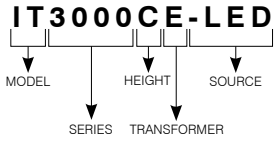

## ORDERING CODE

MODEL	SERIES	HEIGHT	TRANSFORMER	SOURCE
<b>IT</b>	<b>3000</b>	<b>C</b>	<b>E</b>	<b>-LED</b>
<b>IT</b> Remodel	<b>3000</b> 3-1/2" Series	<b>C</b> Short	<b>E</b> Electronic	<b>-LED</b> MR16 LED Lamp



# CONTRASTE